

# XFP

range



1 or 2 loop EN54  
networkable analogue  
addressable fire panels



# 1 or 2 loop EN54 networkable analogue addressable fire alarm panels

## XFP range



XFP single loop 16 zone panel



XFP 1 or 2 loop 32 zone panel

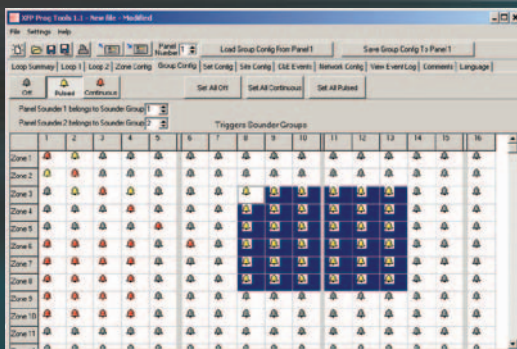

Sophisticated sounder group mapping (above) and complex cause and effect scenarios (below) can be easily implemented using the XFP's intuitive upload-download programming software.

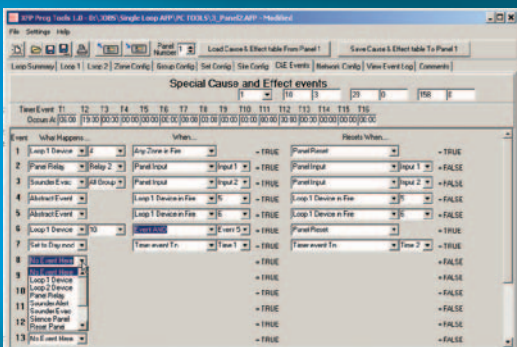

Fully compliant with EN54 parts 2 & 4, C-TEC's XFP range of networkable analogue addressable fire panels offer high performance at a very competitive price.

Available in two different versions (a cost-effective single loop 16 zone panel in a plastic enclosure and a robust 1 or 2 loop 32 zone metal panel), they offer an array of user and installer-friendly features, including:-

- ▶ Full compatibility with Hochiki's ESP and Apollo's XP95, Discovery and Xplorer protocols
- ▶ The ability to interconnect up to eight XFP main panels (any variant) onto a two wire RS485 network (alternatively, up to eight XFP repeaters can be connected to a non-networked XFP main panel)
- ▶ Two independently programmable conventional sounder circuits
- ▶ Two programmable inputs
- ▶ A fault output relay and three programmable relay outputs with voltage free changeover contacts
- ▶ A selection of zone dependency/coincidence functions (allows zones to be individually programmed to be Type A, B or C as detailed below. Type A - If there is an alarm from a detector, the panel will look for a confirmatory alarm from the same or another detector in the same zone before a full alarm is established. If there is no confirmatory alarm, the first alarm will automatically reset. Type B - As Type A except the confirmatory signal must be from another detector in the same zone. Type C - As Type A except the confirmatory signal may also be from another zone, and the first alarm will not automatically reset).
- ▶ A day/night (building occupied/unoccupied) function (allows the operational characteristics of the panel to be changed at a pre-determined time. Engineer programmable day/night changes include detector sensitivity (high/low) and zone dependency settings)
- ▶ An investigation delay period function (programmable for length of time, which zone(s) it applies to and whether or not it operates in day/night mode)
- ▶ Individual sensitivity settings for each device
- ▶ A phased evacuation facility
- ▶ An alarm counter that records the number of times the panel has been in an alarm state (to meet clause 7.13 of EN54-2)
- ▶ Powerful short circuit protected loop drivers, capable of supporting up to 40 loop powered 10mA sounders per loop
- ▶ An integral EN54 switch mode PSU rated @ 185-260V a.c. 50/60Hz (1.4A on 16 zone panel, 3A on 32 zone panel)
- ▶ Earth fault monitoring
- ▶ Push button access code or keyswitch entry to Access Levels 2 and 3 (depending on model purchased)
- ▶ An easy to read, 80 character back-lit display
- ▶ 40 characters of custom text per device
- ▶ 999 event monitoring
- ▶ Comprehensive test, maintenance & commissioning functions (including auto-learn loops, monitor a point, test outputs, one man walk test and loop continuity test)
- ▶ An intuitive Windows based upload-download PC program that allows the system to be programmed quickly and easily

# XFP Technical Specifications

## SINGLE LOOP 16 ZONE XFP PANELS

XFP501E/X; XFP501EK/X  
XFP501E/H; XFP501EK/H

## ONE OR TWO LOOP 32 ZONE XFP PANELS

XFP501/X; XFP501K/X; XFP502/X; XFP502K/X;  
XFP501/H; XFP501K/H; XFP502/H; XFP502K/H

### Power Supply Specification

Mains supply voltage	230V a.c. ± 10% 50/60Hz	230V a.c. ± 10% 50/60Hz
Internal power supply	27V d.c Nominal	27V d.c Nominal
Total output current limited to	1.4A @ 230V a.c.	3A @ 230 V a.c.
Supply and battery charger monitored for failure	Yes	Yes
Batteries monitored for disconnection and failure	Yes	Yes
Batteries protected against deep discharge	Yes	Yes
Max. battery size and type	3.2 Ahr VRLA	7.0 Ahr VRLA
Quiescent current drain (1 loop unloaded)	< 50mA	< 80mA
Quiescent current drain (2 loop unloaded)	not applicable	<100mA
Earth fault monitoring	Yes (any conductor)	Yes (any conductor)
Temperature compensated charging	Yes	Yes

### Loop Driver Specification

Number of loop drivers	1	1 (XFP501/X; XFP501K/X; XFP501/H; XFP501K/H) 2 (XFP502/X; XFP502K/X; XFP502/H; XFP502K/H)
Line monitored for open and short circuit faults	Yes	Yes
Onboard loop isolators with LED indication when active	Yes	Yes
Auto-polling from each loop end	Yes	Yes
Max. loop output current	500mA	500mA
Max. number of addressable devices per loop	126	126
Max. number of loop powered sounders per loop @ 10mA	40	40
Number of programmable sounder groups	16	16
Number of programmable output sets	16	16

### Conventional Sounder Circuit Specification

Number of programmable circuits	2	2
End of line resistor value	6800 Ω 5% Tol. 0.25 W	6800 Ω 5% Tol. 0.25 W
Line monitored for open and short circuit faults	Yes	Yes
Outputs fused at	400mA	800mA
Max. number of sounders @ 20mA	40	80

### Auxiliary Outputs

Type	Relay voltage free single pole changeover
Max switching current	1A
Max switching voltage	30 V d.c
Relay 1	Programmed from cause and effect
Relay 2	Programmed from cause and effect
Relay 3	Programmed from cause and effect
Fault	Active when no faults are present
24V Aux Power Output	100mA. Protected by resettable overload circuit.

### Auxiliary Inputs

Input 1	Connect to 0V to trigger. Max input voltage 27V d.c. (non-latching). Programmable from cause and effect.
Input 2	Connect to 0V to trigger. Max input voltage 27V d.c. (non-latching). Programmable from cause and effect.

### Fuses (to IEC - EN60127 Pt2)

Mains Fuse	1A HRC Ceramic 20mm
Battery Fuse	3A F 20mm

### Panel Indicators and Controls

Control buttons	Silence, Reset, Resound, Investigate; More Information; Menu
Event scrolling and menu access buttons	Up (1); Down (2); Accept (3); Abort (4)
Liquid Crystal Display	Two lines x 40 characters, backlight
Number of Zonal LED indicators	16   32
Other LED indicators	General Fire, System Energised; Pre-Alarm; Remote Output Activated; Menus Accessed; Disablement; Test; Remote Output Disabled; Silenced; General Fault; System Fault;

### Physical Dimensions

Approx. dimensions of back box (W x H x D)	380 x 235 x 77mm (plastic). Includes 'lip'.	410 x 250 x 80mm (metal)
Approx. dimensions of lid (W x H x D)	380 x 235 x 16mm (plastic)	439 x 274 x 7mm (metal)
Approx. weight (without batteries)	1.9Kg	4.5kg

### Cabling Requirements

Type of cable	Fire resistant screened cable, minimum size 1mm <sup>2</sup>
Max. cable length per loop	1km
Connector blocks	Plug-on type, largest acceptable conductor size 1.5mm <sup>2</sup>
Max. allowable loop impedance (each conductor)	20 Ω
Max. cable capacitance	.27μF

### Network Specification

Connection	Via CFP761 network driver card fitted at main panel	Via AFP711 network driver card fitted at main panel
Max. no. of main panels per network	8	8
Max. no. of repeaters per non-networked main panel	8	8
Max. cable length per network	1km (main panel network); 500m (repeater network)	1km (main panel network); 500m (repeater network)

### PC/Printer Interface

PC connection	Via main panel RS232 molex connector (lead supplied in XFP507 upload/download software kit)
Printer connection	Not applicable   Via main panel RS232 connector block.

## TYPICAL WIRING

Below is a diagram of a typical XFP analogue addressable loop fitted with a selection of detectors, loop powered sounders, modules and isolators, all connected to an XFP single loop 16 zone panel. The diagram also illustrates how a series of XFP main panels can be networked using the range's powerful RS485 network.

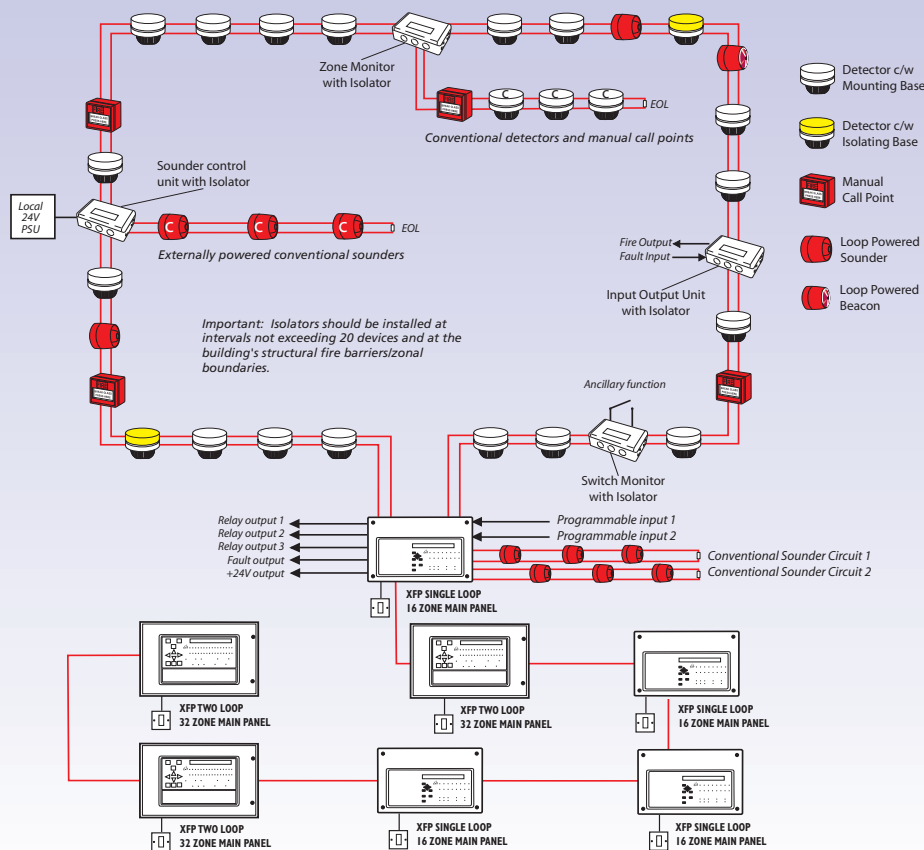

This diagram is provided for illustration purposes only and you should always refer to the relevant XFP panel/device instructions as appropriate before installation. Note that the descriptions and availability of the devices shown may not be applicable to all manufacturer's protocols.

## KEY FEATURES OF THE XFP'S NETWORK PROTOCOL

The XFP's network protocol allows the interconnection of up to eight XFP main panels (any mix) over a two-wire RS485 network. Alternatively, the network can be used to connect up to eight XFP repeaters to one XFP main panel. It is not possible to mix XFP main panels and repeaters on the same network.

### Key features of the XFP's network protocol when used for interconnecting XFP main panels:

- ▶ Allows the interconnection of up to eight XFP main panels (any mix of single loop 16 zone XFPs and 1 and 2 loop 32 zone XFPs)
- ▶ Up to 1 km of cable may be fitted to an XFP main panel network.
- ▶ Each networked XFP main panel can be programmed to accept Fires, Faults and Control actions such as Silence Alarm Sounders and Control Panel Reset from other main panels. They will also Accept Disablement commands for zones, sounders and output sets from other main panels.
- ▶ All panels monitor all other panels for network wiring faults.
- ▶ Fires on remote panels are displayed on local panels including the point description of the alarm's origin.
- ▶ Faults on remote panels are displayed on local panels including the point description of detectors.
- ▶ Cause and effects can be programmed into local panels dependent on which remote panel is in alarm.
- ▶ The network supports the programming of site data into remote panels from a PC at a local panel.
- ▶ Time and date is common to all panels throughout the network.
- ▶ All networked main panels require a network communication card

### Key features of the XFP's network protocol when used for connecting XFP repeaters

- ▶ Allows the connection of up to eight XFP repeaters to one non-networked main panel. The XFP main panel must have a network communication card fitted.
- ▶ Up to 500m of cable may be fitted to an XFP repeater network.
- ▶ Each XFP repeater offers all the functions and controls of an XFP main panel.

## XFP ORDER CODES

### XFP SINGLE LOOP 16 ZONE FIRE PANELS

XFP501E/X	XFP Networkable single loop 16 zone panel (XP95/Discovery) Code entry, c/w 1.4A psu, plastic enclosure
XFP501EK/X	XFP Networkable single loop 16 zone panel (XP95/Discovery) Keyswitch entry, c/w 1.4A psu, plastic enclosure
XFP501E/H	XFP Networkable single loop 16 zone panel (Hochiki ESP) Code entry, c/w 1.4A psu, plastic enclosure
XFP501EK/H	XFP Networkable single loop 16 zone panel (Hochiki ESP) Keyswitch entry, c/w 1.4A psu, plastic enclosure

### XFP 1 LOOP 32 ZONE FIRE PANELS

XFP501/X	XFP Networkable one loop 32 zone panel (XP95/Discovery) Code entry, c/w 3A psu, metal enclosure
XFP501K/X	XFP Networkable one loop 32 zone panel (XP95/Discovery) Keyswitch entry, c/w 3A psu, metal enclosure
XFP501/H	XFP Networkable one loop 32 zone panel (Hochiki ESP) Code entry, c/w 3A psu, metal enclosure
XFP501K/H	XFP Networkable one loop 32 zone panel (Hochiki ESP) Keyswitch entry, c/w 3A psu, metal enclosure

### XFP 2 LOOP 32 ZONE FIRE PANELS

XFP502/X	XFP Networkable two loop 32 zone panel (XP95/Discovery) Code entry, c/w 3A psu, metal enclosure
XFP502K/X	XFP Networkable two loop 32 zone panel (XP95/Discovery) Keyswitch entry, c/w 3A psu, metal enclosure
XFP502/H	XFP Networkable two loop 32 zone panel (Hochiki ESP) Code entry, c/w 3A psu, metal enclosure
XFP502K/H	XFP Networkable two loop 32 zone panel (Hochiki ESP) Keyswitch entry, c/w 3A psu, metal enclosure

### XFP REPEATERS

XFP510-16	XFP Networkable repeater panel, 16 zones (all protocols) Code entry, c/w psu, plastic enclosure
XFP510-16K	XFP Networkable repeater panel, 16 zones (all protocols) Keyswitch entry, c/w psu, plastic enclosure
XFP510-32	XFP Networkable repeater panel, 32 zones (all protocols) Code entry, c/w psu, metal enclosure
XFP510-32K	XFP Networkable repeater panel, 32 zones (all protocols) Keyswitch entry, c/w psu, metal enclosure

### XFP BEZELS

AFP385	Flush mount bezel (for XFP 32 zone main & repeater panels)
--------	--

Note that XFP 16 zone panels have been designed so they can be surface or semi-flush mounted without the need for an additional bezel

### XFP NETWORK COMMUNICATION CARDS

CFP761	XFP network communication card for XFP 16 zone main panels
AFP711	XFP network communication card for XFP 32 zone main panels (One network communication card is required per networked main panel. Note that repeater panels are supplied with a network communication card already fitted).

### XFP PROGRAMMING SOFTWARE

XFP507	XFP Upload download software kit (all protocols) Compatible with Windows 98, 2000, XP
--------	---

### XFP PRINTER KITS

AFP709	XFP off-board printer kit
--------	---------------------------



Quality System Certificate No: 176  
Assessed to ISO9001 : 1994



Manufactured by C-TEC, Stephens Way, Wigan, WN3 6PH. England

UK Sales: Tel: 01942 322744. Fax: 01942 829867. Email: sales@c-tec.co.uk  
European Sales: Tel: +44 1942 322744. Fax: +44 1942 829867. Email: eu.exports@c-tec.co.uk  
Export Sales: Tel: +44 161 257 2541. Fax: +44 161 225 8817. Email: xportsales@xportsales.com

© 2005-2007 Errors and omissions excepted. C-TEC operates a policy of continuous improvement and we reserve the right to alter product specifications at our discretion and without prior notice. Approved Document No. DFS0380497 Rev 3

